

1. GENERAL DESCRIPTION

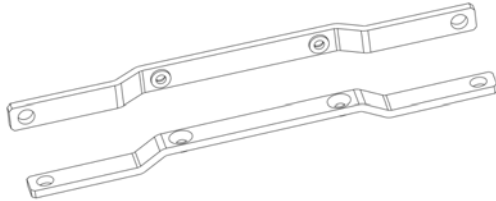

BRACKET FOR WALL MOUNTING

This accessory is used to mount Dimension power supplies and other Dimension units on a wall or on a panel without using a DIN-Rail.

The two aluminum brackets and the black plastic slide must be removed from the unit, to allow mounting of the two zinc-plated steel brackets.

2. INSTALLATION DATA

Fig. 2-1 Unit equipped with wall mounting brackets

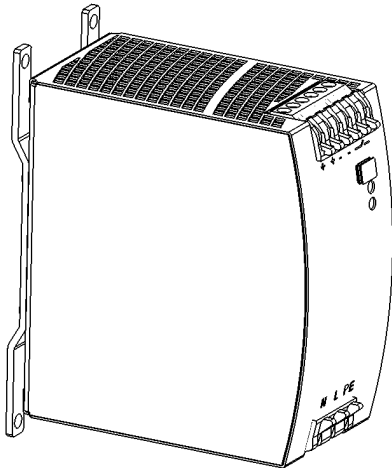
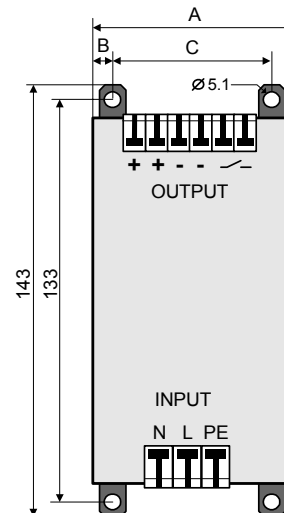

Fig. 2-2 Mounting dimensions



Unit	A	B	C
CD5.XXX	32mm	4.8mm	22.5mm
CS3.XXX	32mm	4.8mm	22.5mm
CS5.XXX	32mm	4.8mm	22.5mm
CS10.XXX	60mm	5.8mm	48.5mm
CT5.XXX	40mm	5.0mm	30.0mm
CT10.XXX	62mm	5.7mm	50.6mm
QS3.XXX	32mm	4.8mm	22.5mm
QS5.XXX	40mm	5.3mm	29.5mm
QS10.XXX	60mm	5.8mm	48.5mm

Unit	A	B	C
QT20.XXX	65mm	6.3mm	40.0mm
QTD20.XXX	65mm	6.3mm	40.0mm
QS20.XXX	82mm	8.0mm	66.0mm
QS20.244	70mm	8.0mm	54.0mm
UF20.XXX	64mm	12.0mm	40.0mm
UB10.XXX	49mm	5.3mm	38.4mm
YR2.DIODE	32mm	4.8mm	22.5mm
YRM2.DIODE	32mm	4.8mm	22.5mm

3. ORDER NUMBERS

Accessory **ZM1.WALL** 2 pcs. wall-mounting brackets; 8x143x7mm,
The order number consists of a set with two brackets suitable for one unit

4. ASSEMBLY AND MOUNTING INSTRUCTIONS

Fig. 4-1 Detaching DIN-Rail brackets

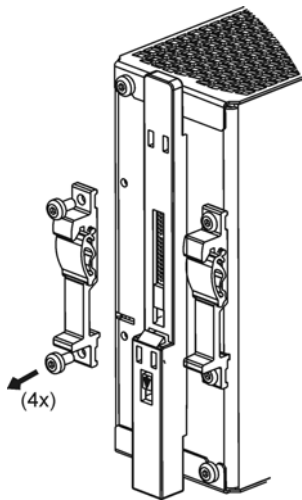

Detach the two aluminium brackets by removing the four screws with a Torx screwdriver (Torx 10). Save the screws for step 3.

Fig. 4-2 Detach slide

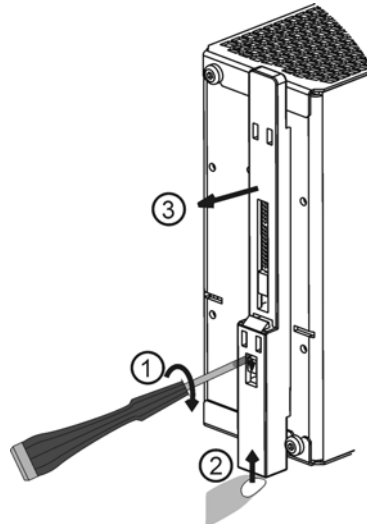

Remove the plastic lock mechanism by using a flat-blade screwdriver to move the lock downwards while at the same time push the plastic slide upwards. Detach the plastic slide.

Fig. 4-3 Mounting steel brackets

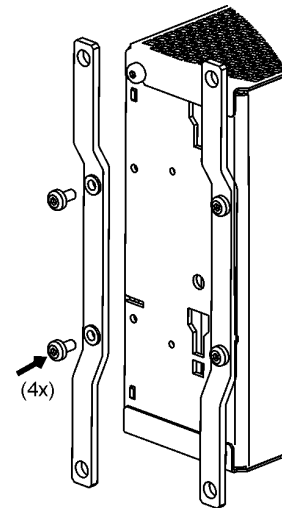

Mount the two steel brackets with the same screws from the DIN-Rail brackets using caution not to over-tighten the screws! Recommended tightening torque is 0.6Nm. (5.3lb.in).

5. PHYSICAL DIMENSIONS AND WEIGHT

Weight 25g / 0.06lb each
50g / 0.11lb for one set

Electronic files with mechanical data can be downloaded at www.pulspower.com

Fig. 5-1 Dimensions

